

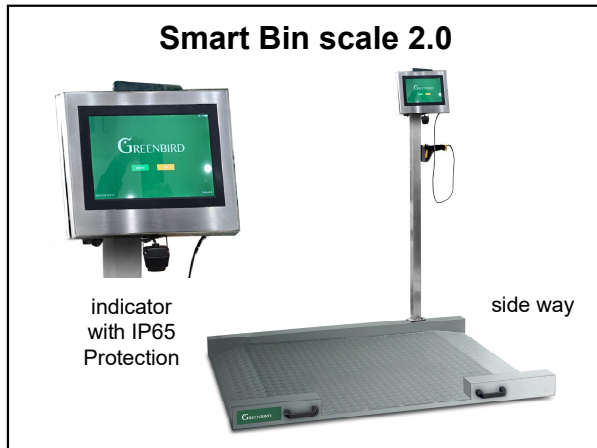

**MASTERK**  
THE MASTERS OF INDUSTRIAL WEIGHING

**萬特佳**

# Smart Bin Scale 2.0



## Description

- ➔ - Android 11 system with 10.1" color TFT-LCD display and touch screen
- Powered by Greenbird 2.0 Application
- Stainless steel 304 weigh indicator with IP65 protection
- WiFi, Bluetooth 4.2, & supports 4G LTE / GPS connectivity
- USB port supports cable or wireless QR code scanner
- IP65 camera available
- USB port for CSV data export supported by USB flash drive
- High precision weighing sensor with IP67 protection
- Built-in rechargeable battery and speaker for voice functionality
- With the side way for 240L Bin

## Plan/Size

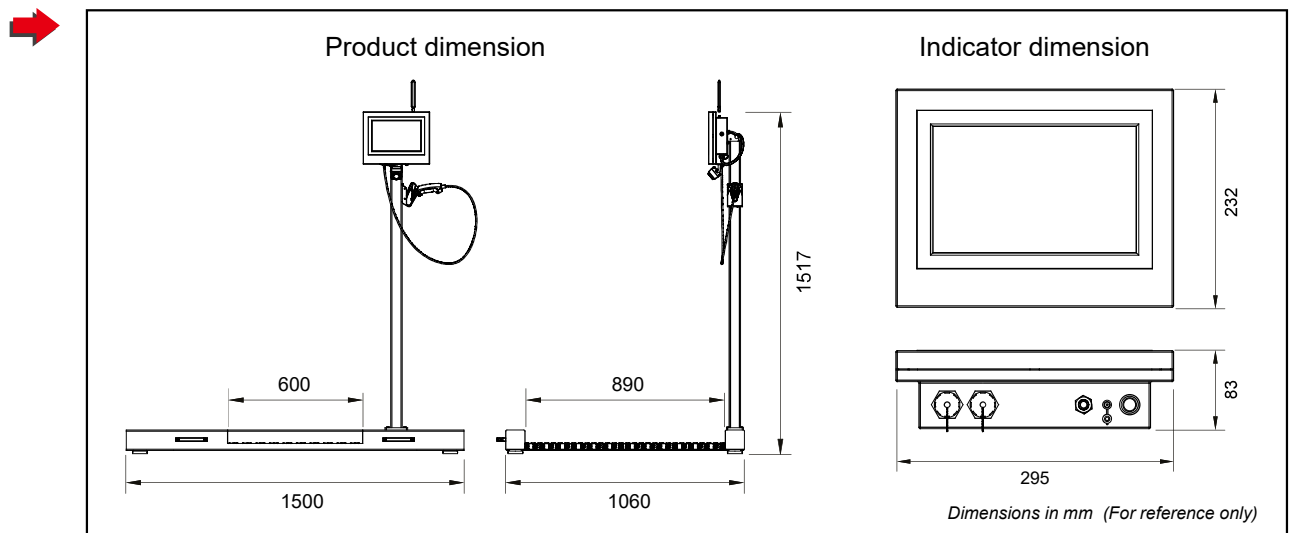



# MASTERK

THE MASTERS OF INDUSTRIAL WEIGHING

# 萬特佳

## Characteristics

### INDICATOR CHARACTERISTICS

Max capacity	500kg
Graduation	200g
Waterproof	IP65
Case material	Stainless Steel 304
Display	10.1" color TFT-LCD
Panel Interface	Capactive Touch Panel
Connectivity	WiFi, 4G LTE/ GPS supported, Bluetooth 4.2
Processor	RK3568
RAM	2G
System Type	Android 11
System Storage	32GB
USB port	2
QR code scanner	USB port for Cable & Wireless (optional)
USB data output	CSV data output via USB Flash
Application	Greenbird 2.0
Speaker	Build-in speaker for voice function
Power	AC adapter
Battery	Build-in rechargeable battery 12V 11,000mAH (up to 9 hours)
Indicator Size	232 x 295 x 83mm (for reference only)

### SCALE CHARACTERISTICS

Platform size	1500 x 1060mm
Stainless steel pole	Rectangular 50mm x 50mm
Indicator supporter	Stainless steel indicator adjustable supporter (20-90 degree)
Platform finishing	Grey powder coating
Platform plate	Anti-skid pattern
Ramp length	20cm
Slope degrees	7°
Bin use	Fit for DIN EN480 bin standard
Feet	Adjustable
Overall size	1500 x 1060 x 1526 mm (for reference only)

THE MASTERS OF INDUSTRIAL WEIGHING

