



MASTERK
THE MASTERS OF INDUSTRIAL WEIGHING

萬特佳

Smart Trolley Scale



Description

- ➔ - All-In-One Weighing Indicator with smart transfer data solution
- Highly movable and easy to use in wide range of environment
- Build-in rechargeable battery
- Build-in Bluetooth 4.0 & USB for data upload through Cloud as Big Data Analysis
- QR code scanner (optional)
- Display (128 x 64 pixels) with white backlight
- User Friendly Keypad, only 4 keys (Set - Up – Down – Print/Enter)

Plan/Size

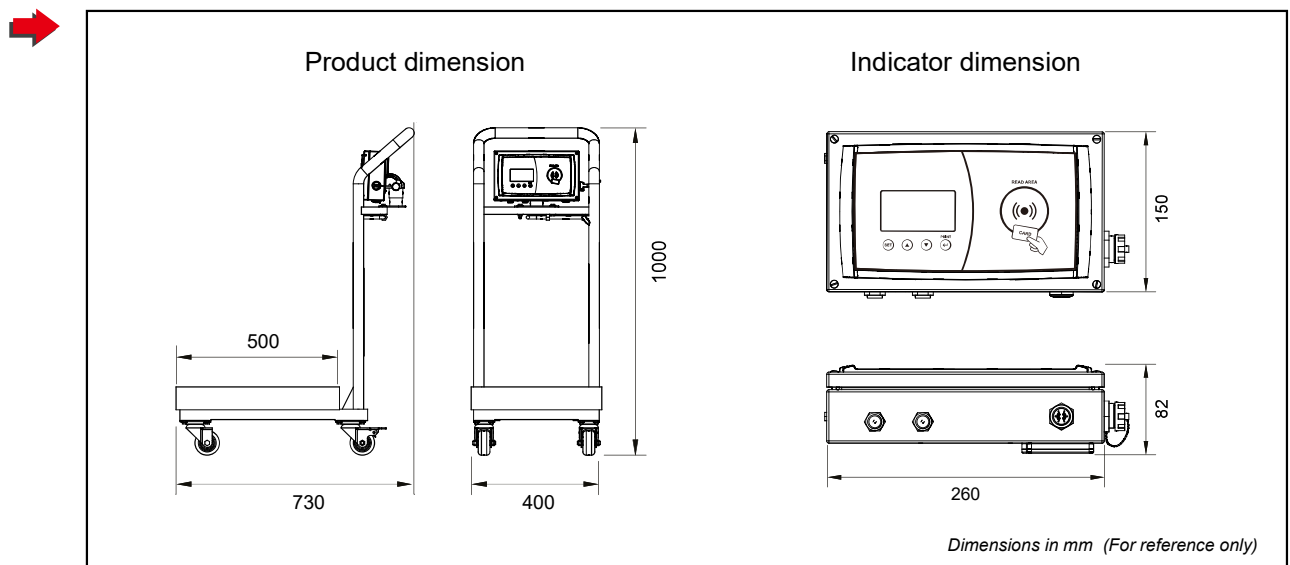

THE MASTERS OF INDUSTRIAL WEIGHING





MASTERK

THE MASTERS OF INDUSTRIAL WEIGHING

萬特佳

Characteristics

INDICATOR CHARACTERISTICS

Capacity	150kg
Graduation	50g
Waterproof level	IP65
Case material	Stainless Steel
User input	Smart card / Waste type IC card / QR code scanner (optional)
Buttons	Set, Up, Down, Print/Enter
Output	USB
Display	(128x64 pixel) with white backlight
Display size	73 x 40mm
Power	AC adapter
Battery	Build-in rechargeable battery
Wireless technology	Bluetooth 4.0
Connector plug	Aviation connector plug
Indicator Size	150 x 260 x 82mm (for reference only)

SCALE CHARACTERISTICS

Platform size	500 x 400mm
Indicator supporter	SS indicator adjustable supporter (20-90 degree)
Platform finishing	Stainless steel hair line brush
Frame	Steel welded frame
Wheels	Trolley with 4 wheels
Overall size	1000 x 730 x 400 mm (for reference only)

THE MASTERS OF INDUSTRIAL WEIGHING

