



**MASTERK**  
THE MASTERS OF INDUSTRIAL WEIGHING

**萬特佳**

# Carry on baggage checker



## Description

- ➔ - Weighing & Dimension checker
- Stainless steel weighing platform
- Stainless steel frame for checking dimension
- Power saving LCD readout, 15mm (0.6") digit
- Powered by Battery or DC adapter
- User Friendly Keypad, 3-buttons operation

## Plan/Size

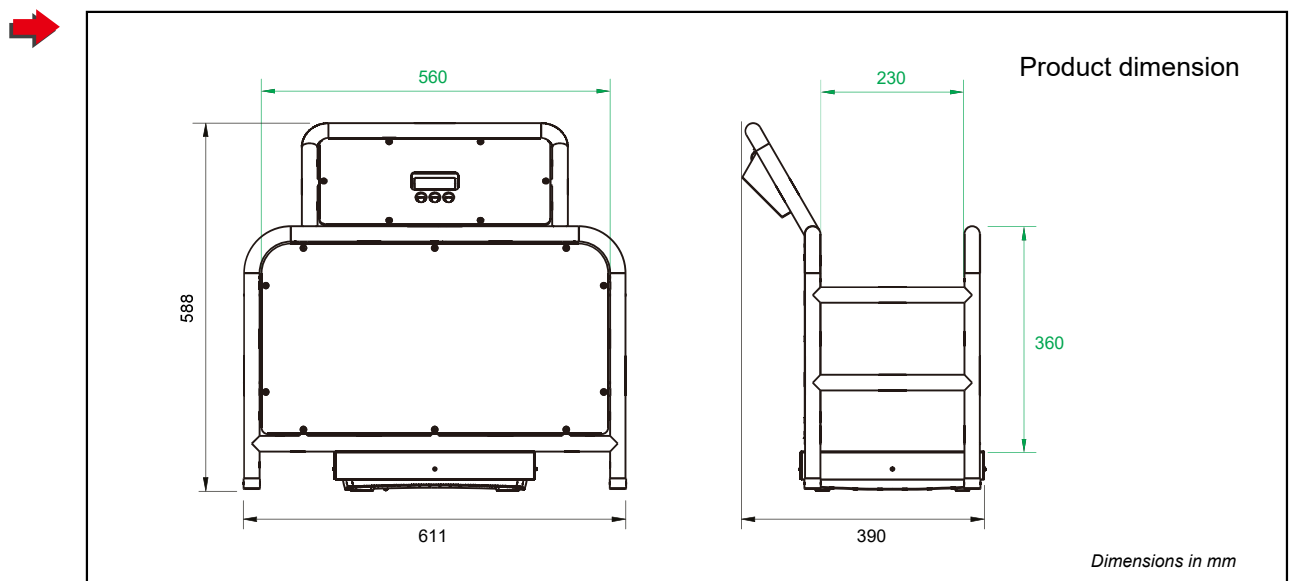

THE MASTERS OF INDUSTRIAL WEIGHING





# MASTERK

THE MASTERS OF INDUSTRIAL WEIGHING

# 萬特佳

## Characteristics

### WEIGHING

Max capacity	50kg or 110lb
Graduation	20g or 1oz
Weighing platform	Stainless Steel
Buttons	On/Tare, Off, Unit
LCD readout	15mm (0.6") digit
LCD View area	65 x 21mm
Powered by	DC adapter or 1 x 9V alkaline battery
Unit	kg or lb

### BAGGAGE DIMENSION CHECKER

Baggage size limitation	560 x 360 x 230mm (can be custom made as per customer request)
Frame	Stainless steel welded frame
Overall size	615 x 590 x 390mm

THE MASTERS OF INDUSTRIAL WEIGHING

