



Smart Trolley Scale 2.0



Description

- ➔ - Android 11 system with 10.1" color TFT-LCD display and touch screen
- Powered by Greenbird 2.0 Application
- Weigh indicator of Stainless steel 304 case with IP65 protection rating
- WiFi, Bluetooth 4.2, & supports 4G LTE / GPS connectivity
- USB port supports QR code scanner (cable or wireless) and camera available
- USB port for CSV data export supported by USB flash drive
- High precision weighing sensor with IP67 protection rating
- Built-in rechargeable battery and speaker for voice functionality
- Trolley with four wheels for easy mobility

Plan/Size

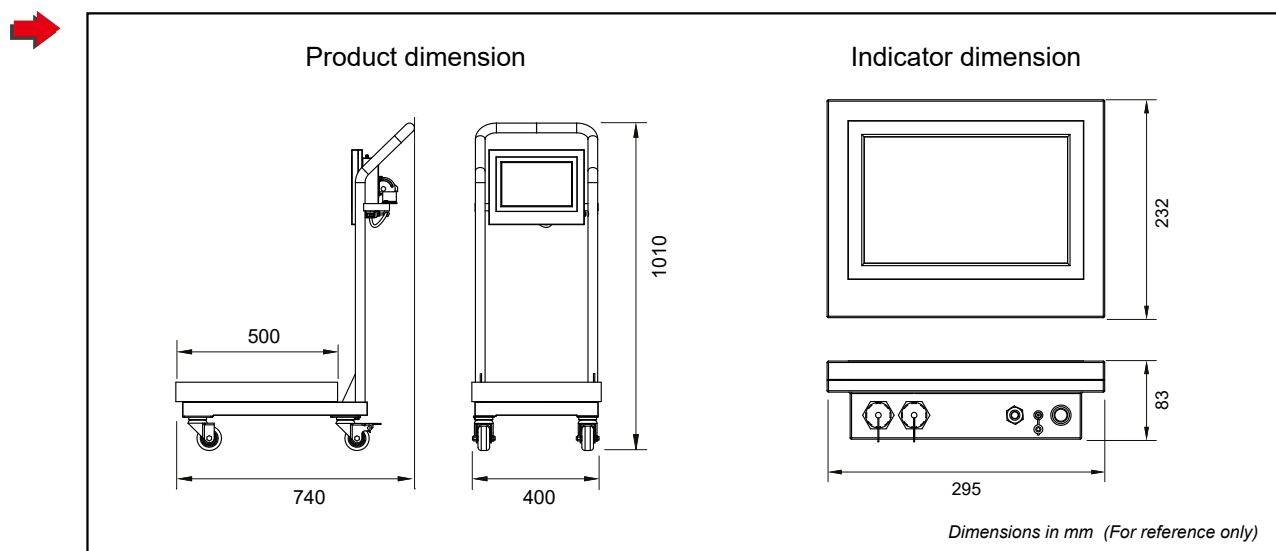



MASTERK

THE MASTERS OF INDUSTRIAL WEIGHING

萬特佳

Characteristics

INDICATOR CHARACTERISTICS

Capacity	150kg
Graduation	0.05kg
Minimum weight	0.1kg
Indicator protection	Rating IP65
Case material	Stainless Steel 304
Display	10.1" color TFT-LCD
Panel Interface	Capactive Touch Panel
Connectivity	WiFi, 4G LTE/ GPS supported, Bluetooth 4.2
Processor	RK3568
RAM	2G
System Type	Android 11
System Storage	32GB
USB port	2
QR code scanner	USB port for Cable & Wireless (optional)
USB data output	CSV data output via USB Flash
Application	Greenbird 2.0 Application
Speaker	Build-in speaker for voice function
Power	AC adapter
Battery	Build-in rechargeable battery 12V 11,000mAH (up to 9 hours)
Indicator Size	232 x 295 x 83mm (for reference only)

SCALE CHARACTERISTICS

Platform size	500 x 400mm
Platform finishing	304 stainless steel with hairline brushed finish
Frame	welded steel construction
Wheels	4-wheel trolley design
Handrail	Ergonomic waist-level handrail for enhanced durability
Indicator supporter	Stainless steel adjustable indicator bracket (adjustable from 20° to 90°)
Overall size	1010 x 740 x 400 mm (for reference only)
Weighing sensor	IP67 load cell

THE MASTERS OF INDUSTRIAL WEIGHING

